

VISTA PAREDE 01

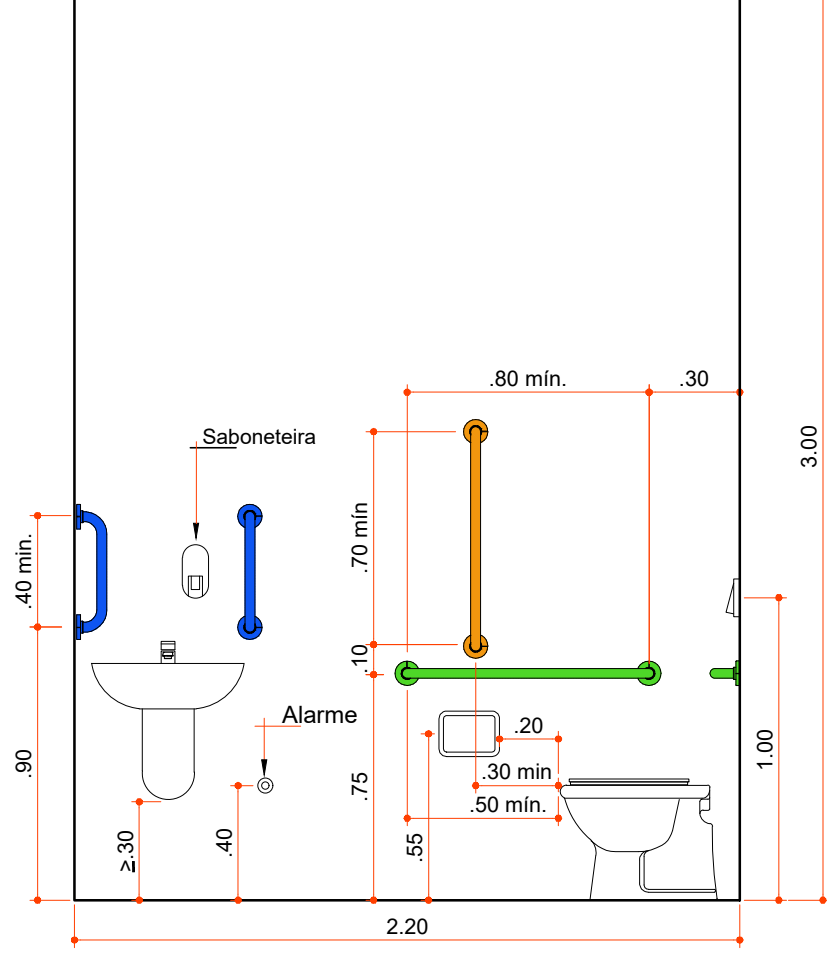

VISTA PAREDE 02

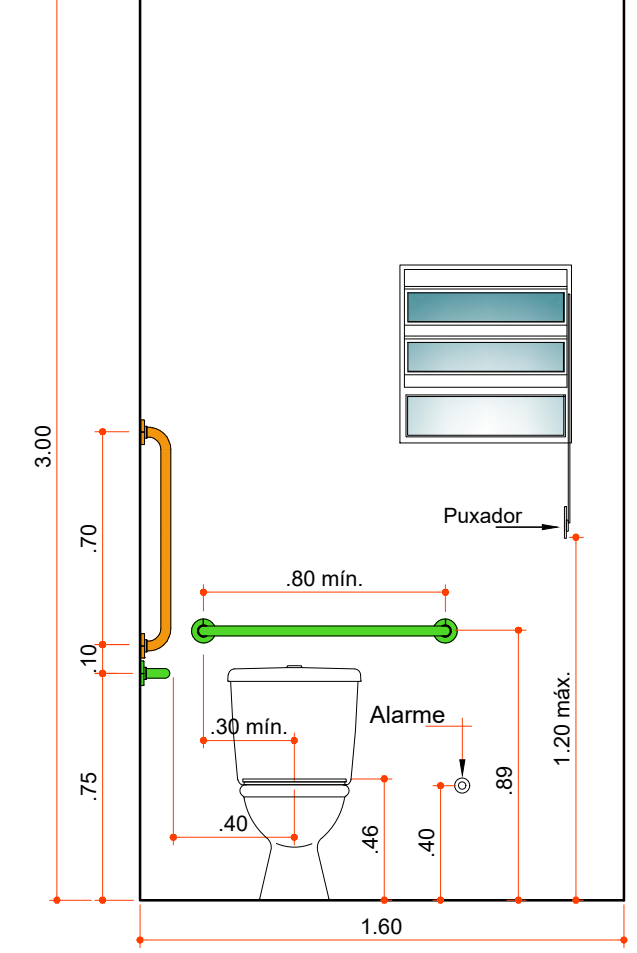

VISTA PAREDE 03

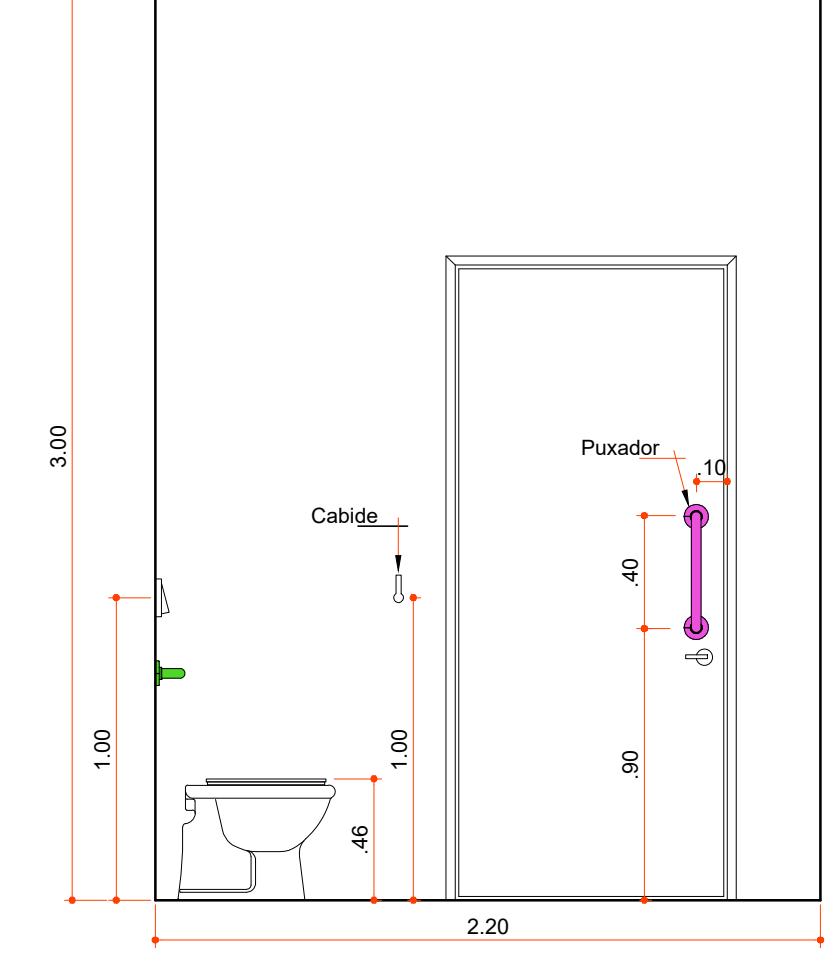

VISTA PAREDE 04

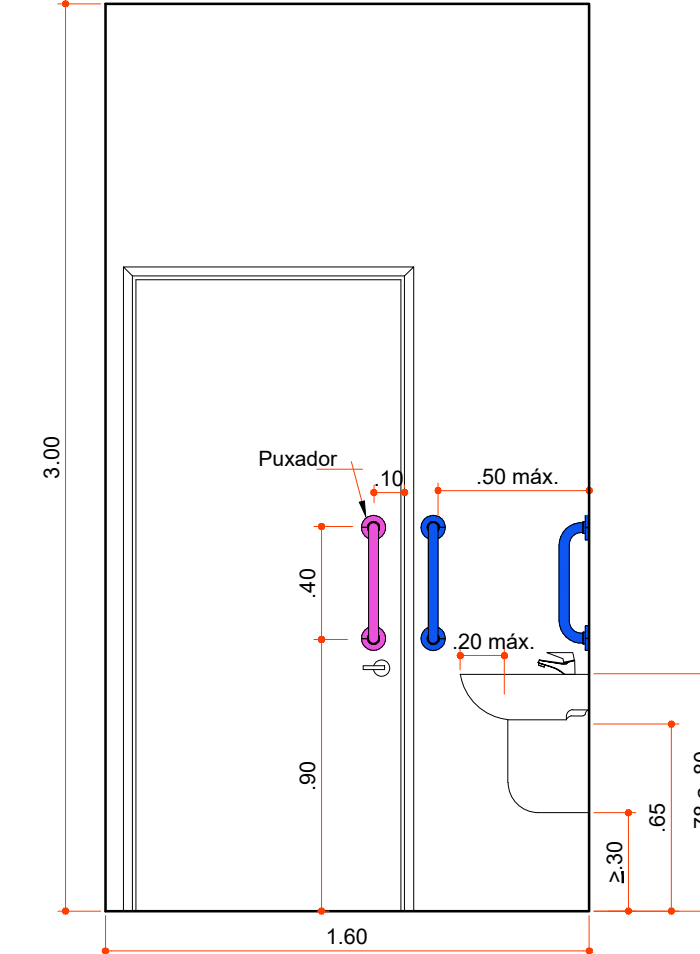
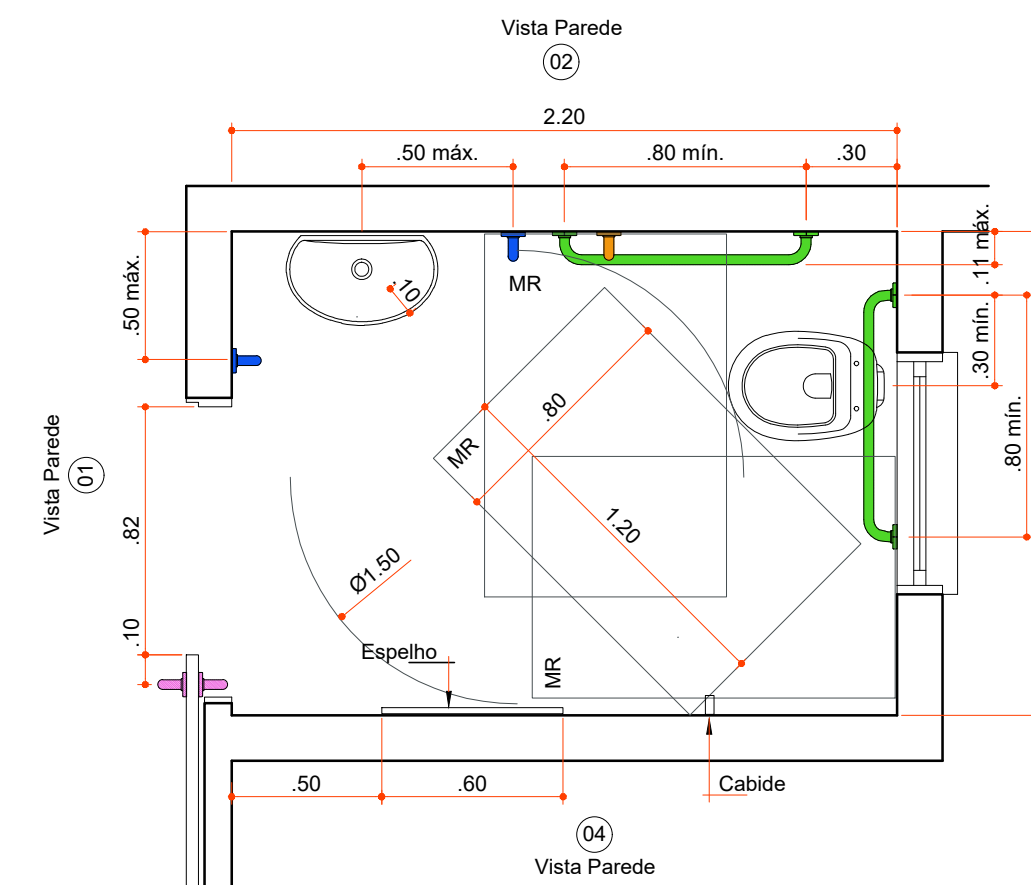

VISTA PAREDE 01

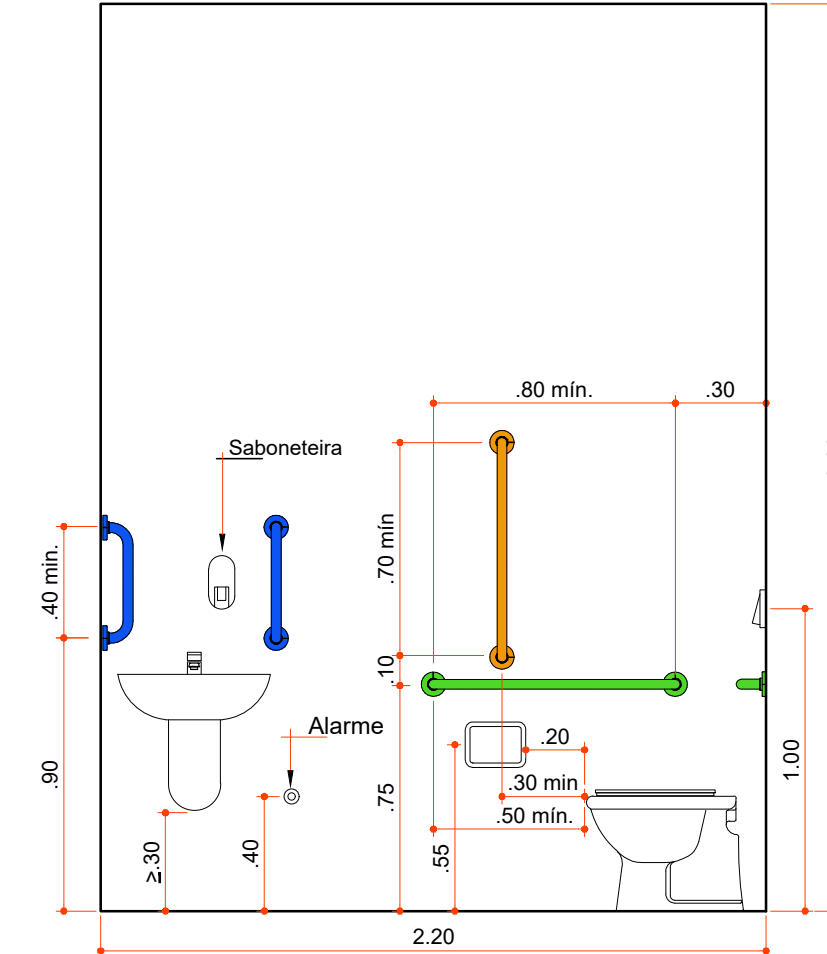

VISTA PAREDE 02

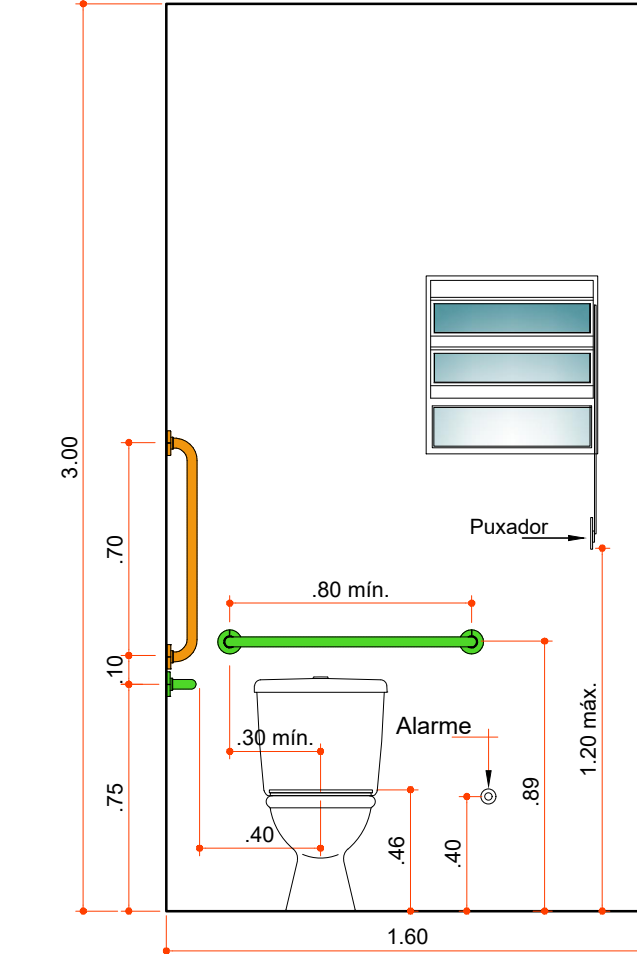

VISTA PAREDE 03

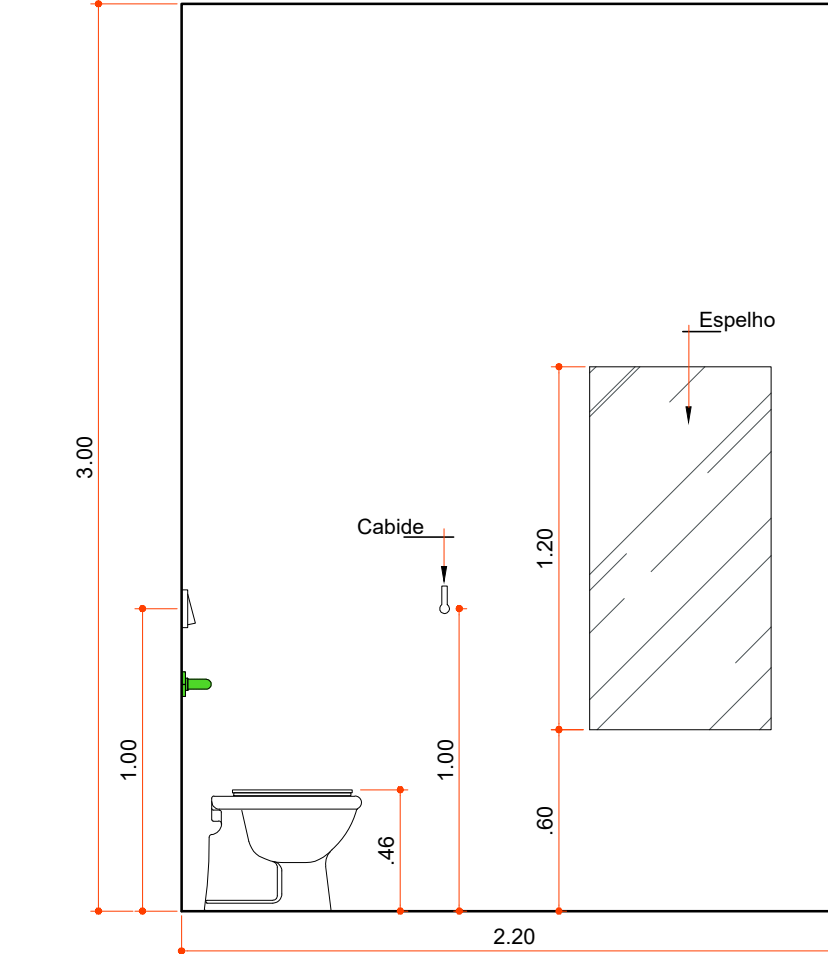

VISTA PAREDE 04

Aprovações:

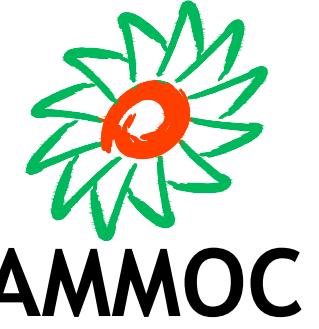

Rua Roberto Trompowski, 68 - 2º andar / Tel: 49 3522-2800 - www.ammoc.org.br - e-mail: ammoc@ammoc.org.br - Joaçaba/SC

PREFEITURA MUNICIPAL DE VARGEM BONITA

Obra: **REFORMA E ALTERAÇÃO DE LAYOUT UBS E SECRETÁRIA DE SAÚDE**

Local da Obra: **ESTRADA MUNICIPAL - LINHA CORAÇÃO**

Conteúdo: **DETALHES CONSTRUTIVOS**

Responsável Técnico:
 Ana Júlia U. de Carvalho - Eng. Civil - Crea/SC 105.295-8
 André Brito Dotti - Eng. Civil - Crea/SC 162.237-5
 Denir Narcizo Zulian - Eng. Civil - Crea/SC 50.805-8
 Fábio Zilio Caron - Eng. Civil - Crea/SC 140.642-7
 Lucas F. Balestrin - Eng. Agrônomo - Crea/SC 156.743-7
 Max Mooshammer - Eng. Civil - Crea/SC 139.164-0
 Suellen Karine Cervelin - Eng. Civil - Crea/SC 166.933-0

ARQ
03/03

Quaisquer alterações consulte os responsáveis técnicos:

Assinatura Responsável Técnico	Assinatura Prefeito(a) Municipal
Desenho: Fernando A.	Data: Agosto / 2021
Escala: Indicada (s)	Área Total: 127,16 m ²